

THE FO'C'STLE

NO.10 SPRING 2005, PUBLISHED SEMI SPAZMODICALLY

A newsletter for the sailing community of Milwaukee and Southeast Wisconsin.

*Challenge
1851*



CRAMERMARINE.COM
CRAMERMARINE@WI.RR.COM

CRAMER MARINE, INC., 880 W. CANAL ST. MILWAUKEE WI, 53233, 414-272-5998

Have Faith

Hurricane Francis just about ended Frank Steeve's Faith. His Niagra 35 that is. Faith, moored in Fort Meyers, FL was almost totaled when floating concrete piers left their moorings and crashed into Frank's yacht. Damage included: hull gelcoat, the bow pulpit, bow sprit, stanchions, three interior bulkheads, radar mount, stern rail boarding ladder, genoa lead tracks, major damage to the port toe rail and completely removing the molded-in starboard toe rail. Was it a total loss or could it be saved? Considering: Frank's affection for the boat, another boat would probably have ended up at the

bottom of the ocean and a slot in the work schedule of Cramer Marine, it was decided to have the boat shipped north and reassembled by their experienced craftsmen. Given that the major damage was the starboard toe rail, it was decided to address that first. The reconstruction included actually glassing the hull and the deck together and then constructing a new toe rail and placing it on top. Construction of the original the toe rail was half molded to the deck and half molded to the hull and then bolted together. Here, it was felt that actually glassing the deck to the hull would speed the reconstruction and ultimately form a stronger boat.

Below Al and Mike check dimensions of the new rail before glassing it in place.



2005 Miami Boat Show

Without a doubt the high light of the show and also probably the biggest reason for going was the 78° F temperature and the cloudless sky. Yale Cordage introduced "Brait". A single braid, 8 strand nylon anchor line. Immune to kinking and hockling with greater energy absorption. (After doing a little investigation, I discovered that New England Ropes has had a 12 strand version on the market for at least a year. Where have I been?) Definitely something worth checking out. Good Turns, LLC introduced a product called the **TURNCOUPLE**. A plastic 1 1/2" pipe coupler with RH threads on one side and LH threads on the other side. In conjunction with their LF threaded male pipe fitting, two pieces of pipe can be quickly joined or disconnected like a turnbuckle. Maybe to connect and disconnect a head discharge hose when leaving and entering restricted waters. The Forespar "Hoyt" jib boom continually undergoes design upgrade and becomes ever more attractive. I feel confident we'll see it on at least one boat in Milwaukee this year. I can't decide if the new boats on display are there for our pleasure or punishment. Half the new boats there were catamarans. Up to 70 ft. Must be seen to be believed!

MIDWEST'S
LARGESTS



IN-BOOM
FURLING
DEALER

CRAMER MARINE, INC.
 880 W. CANAL ST.
 MILWAUKEE, WI 53233



**Up -
 Grades**
 By Stubby Phillips

Thanks to skipper Jim Calder for making me aware of the mistake in the alarm circuit printed in this column in the last issue. The corrected circuit is shown below. The desired alarm circuit can also be accomplished with a typical "normally closed" oil pressure switch, but this requires a fourth relay. Next issue we'll add the engine cooling water high temperature alarm.

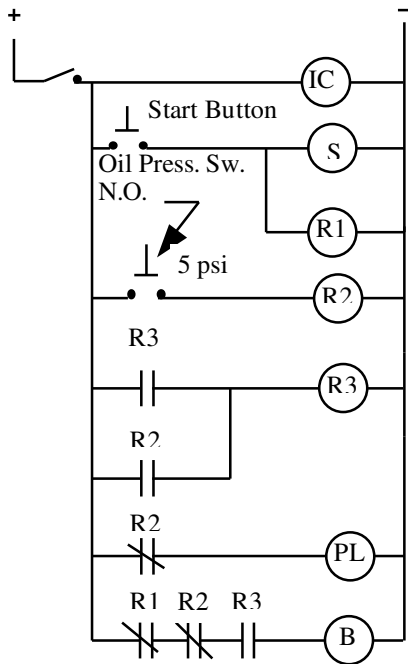

Authorized
Raymarine
 Dealer
 Installer

"I'd rather be sailing to nowhere, than do anything else on the land".

-Michael McCloud

Boat Building

Hull no 1 of the "Vega" class rolled off the production line at Cramer Marine this winter. A slightly modified Joel White "Martha's Tender" design. Wooden Boat Magazine printed building plans in 1982. Cramer Marine intends on using the prototype to determine a pricing structure and generate sales. Pictured below is the mold frame and hull #1 all planked and ready to be set free. Keep a weather eye peeled for Vega gracefully rowing around the McKinley Marina.



CRAMER MARINE, INC.
 IS YOUR COMPLETE
 SALES AND SERVICE
 CENTER FOR:



Sheepshead Tiller

Captain Marge Beil, owner of the Shearwater has requested of Cramer Marine the construction of a Sheepshead tiller. A new shorter, interchangeable tiller, long enough to function with the auto-pilot, yet enable card playing in the cockpit. Marge has been known to say that on a long trip, "There's nothing like a little 5-10-15, double on the bump."