

THE FO'C'STLE

NO. 9 WINTER 2003/4

A newsletter for the sailing community of Milwaukee and southeast Wisconsin.

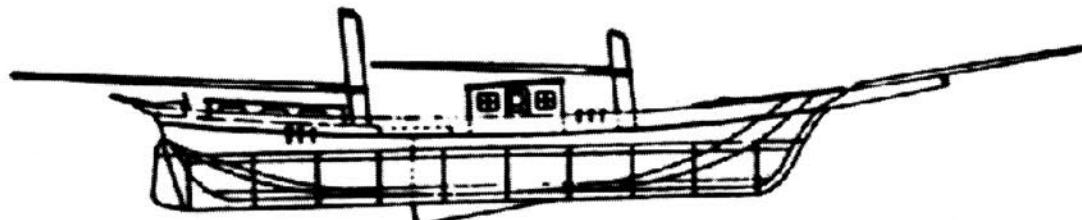

CRAMER MARINE, INC., 880 W. CANAL ST. MILWAUKEE WI, 53233, 414-272-5998

BULLY MOSES LANGE by Sloop John E.

Oft of a night in a little ghost town,
Bully Moses Lange'd stop for a round
At a dim, dingy tavern o'er lookin' the bay,
And drink till the tender'd call it a day.

One night old Moses was later than most
And so missed 'is seat at his usual post;
'Twas filled by the pants of a sailor of fame—
Apple Johnny Patch they said was his name.

Now Mose had done more'n his usual share
And the workin' was hot in the salty sea air;
So hot fired and bone weary he entered the pub,
And soon as he entered John Patch gave a rub.

He said, "Mose, the boys tell me that this is your chair!
Well, fat man, today someone's already there."
Mose in his rage grabbed a mug o' draft beer
And nigh with his throw tore the top off John's ear.

Patch went for his knife, but Lange saw the move
And rushed on the sailor, his hands on the loose,
Bare fist met bare jaw, its mate found a nose,
But not before John plunged his knife into Mose.

Moses Lange crumpled forward—his belly was stained.
His eyes turned to glass and mirrored his pain.
But Mose held no grudge; he said, "Guess I'm all through.
I wish I'd 'a known what John Patch aimed to do."

Moses died on the bar floor, at peace with the Lord
He didn't make saint, but he managed his board.
Apple John hopped a schooner bound for the cape;
He jumped o'er the side to his non ending fate.

Now oft of a night in a little coast town,
The shipmen, less one, stop in for a round
At a dim dingy tavern o'er lookin' the bay,
And drink till the tender calls it a day.

Consignment Items Priced to Sell

- ♦ Auto Pilot, Simrod #30 \$560
- ♦ Harken Furling Unit #0, \$500
- ♦ Yanmar 2 GMF \$3,500
- ♦ Winches, Barreint #27, pr \$550

The 9th Annual ROADTRIP!

"Strictly Sail Boat Show"

Navy Pier, Chicago, Ill

January 31, 2004

Departing Milwaukee Yacht
Club Parking Lot. 8:00 AM

Returning (leaving Navy Pier)
4:00 PM

Cost: \$20.00 Does not include ad-
mission to show.

Make your reservation by check
or cash to Cramer Marine. Must
be received by **Friday, January
23, 2004.**

Brokerage Boat of the Month

Must Sell!

Cal 2-30, \$10,000



CRAMER MARINE IS YOUR
AREA DEALER FOR THIS
WORLD WIDE RECOGNIZED
LEADER OF INBOOM FURL-
ING SYSTEMS. WE CUR-
RENTLY HAVE TWO IN OPERA-
TION. STOP IN FOR A DEMO.

CRAMER MARINE, INC.
880 W. CANAL ST.
MILWAUKEE, WI 53233



MVP

(Most Valuable Product)

ENVIRO-BOND,
Bilge Socks. Absorbs
and solidifies oil, gas
and diesel fuel.

Up - Grades

By Stubby Phillips

In a previous column I stressed the need for an audible alarm on your engine's crankcase oil pressure system. The red warning just isn't sufficient. It's necessary but not sufficient. So how are you going to install it?

You could wire it parallel to the warning light. This would definitely do the job. But, your engine is low in the bilge and you want the audible alarm close to you in the cockpit so you can hear it. Now, when starting the engine, what if, the alarm drowns out the engine so you can't hear it crank. And when you first turn on the key, it's not necessary for the alarm to sound because it's not in an alarm situation. That sure is a lot of "ands". Well nobody said that circuit design logic makes for good literature.

Late model diesels do all of this with a computer chip.

Follow the simple wiring diagram here and you will eliminate the pitfalls mentioned above. R1, R2 and R3 are 12v DC re-

lays, obtainable at Radio Shack. B is the buzzer. PL is the red warning light. S is the starting motor solenoid and IC is the ignition circuit. You may be putting this on your diesel and I know diesels don't have ignition systems, but what else are you going to call it?

If you have any questions you may email me at cramermarin@aol.com. The good people there will forward your request.

Next time we'll talk about the alarm installation on the cooling water system.

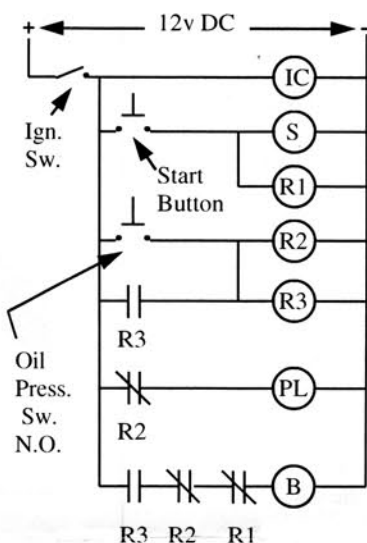

CRAMER MARINE, INC.
IS YOUR COMPLETE SALES
AND SERVICE CENTER FOR:



YANMAR
DIESEL AMERICA CORP.



**Some projects of interest
this winter at the yard**

- ◆ *Four To Go*, Atomic IV rebuild
- ◆ *Challenge* gets an Alwgrip paint job
- ◆ *Time Goes By* converts to cutter rig
- ◆ *Smuggler* gets a new Yanmar
- ◆ *Harmony*, mast; splice repair and Alwgrip paint job



Sail Away Sails

Marine Canvas, Sails and Sail Repairs

414-272-5998